



Designed for life.™

LIMITED SERIES

T605

T805



Treadmill User's Guide

Table of Contents

IMPORTANT PRECAUTIONS3
ASSEMBLY5
BEFORE YOU BEGIN9
TREADMILL OPERATION12
TROUBLESHOOTING18
CONDITIONING GUIDELINES21
LIMITED WARRANTY29

Important Precautions

SAVE THESE INSTRUCTIONS

Read all instructions before using this treadmill. When using an electrical product, basic precautions should always be followed, including the following: Read all instructions before using this treadmill. It is the responsibility of the owner to ensure that all users of this treadmill are adequately informed of all warnings and precautions.



WARNING! Connect this exercise product to a properly grounded outlet only. See grounding instructions.

GROUNDING INSTRUCTIONS

This product must be grounded. If a treadmill should malfunction or breakdown, grounding provides a path of least resistance for electrical current to reduce the risk of electrical shock. This product is equipped with a cord having an equipment-grounding conductor and a grounding plug. The plug must be plugged into an appropriate outlet that is properly installed and grounded in accordance with local codes and ordinances.

DANGER! Improper connection of the equipment-grounding conductor can result in a risk of electric shock. Check with a qualified electrician or serviceman if you are in doubt as to whether the product is properly grounded. Do not modify the plug provided with the product. If it will not fit the outlet, have a proper outlet installed by a qualified electrician.

This product is for use on a nominal 120-volt circuit, and has a grounding plug that looks like the plug illustrated below. A temporary adapter such as the one illustrated below may be used to connect this plug to a 2-pole receptacle as shown, if a properly grounded outlet is not available. The temporary adapter should be used only until a properly grounded outlet can be installed by a qualified electrician. The green colored rigid ear, lug, or the like extending from the adapter must be connected to a permanent ground such as a properly grounded outlet box cover. Whenever the adapter is used, it must be held in place by a metal screw.

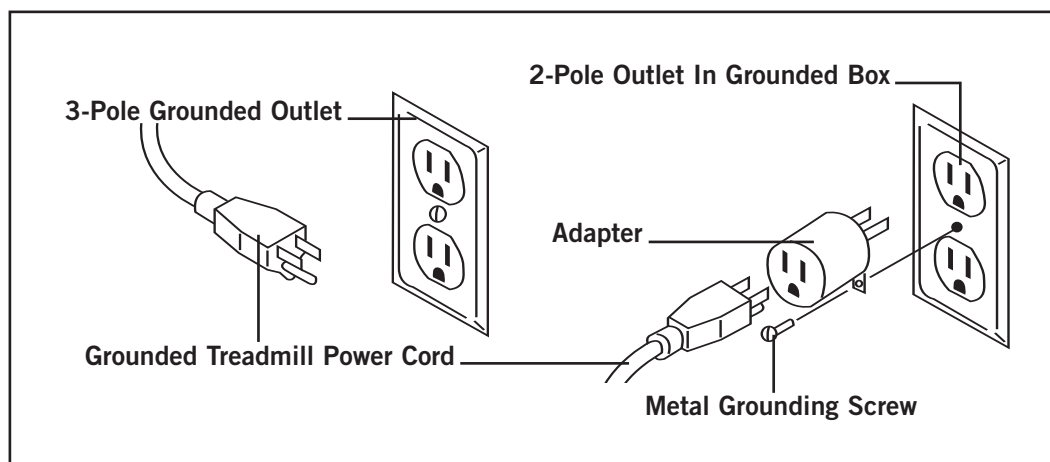



WARNING! To reduce the risk of burns, fire, electrical shock or injury to persons:

- Never use the treadmill before securing the safety tether clip to your clothing.
- If you experience chest pains, nausea, dizziness, or shortness of breath, stop exercising immediately and consult your physician before continuing.
- Do not wear clothes that might catch on any part of the treadmill.
- Keep power cord away from heated surfaces.
- Keep children off of treadmill at all times.
- Do not use treadmill in garages, porches, car ports or outdoors.
- The treadmills are intended for in-home use only. Do not use this treadmill in any commercial, rental, or institutional setting.
- Unplug treadmill before moving it.
- Do not remove the treadmill motor covers or roller covers. Service should be performed only by an authorized service provider.
- At no time should more than one person be on treadmill while in operation.
- Keep children under the age of 12 and pets at least 10 feet away from the treadmill at all times.
- The treadmills should not be used by persons weighing more than 250 pounds (T605) & 275 pounds (T805).
- Clean with soap and slightly damp cloth only; never use solvents.

OTHER SAFETY TIPS FOR YOUR TREADMILL



OPERATION

To reduce the risk of damaging important components on your treadmill, it is strongly recommended that your treadmill is plugged into a dedicated **20amp outlet, without the use of an additional extension cord. IMPORTANT: The treadmill is not compatible with GFCI-equipped outlets.**

It is essential that your treadmill is used only indoors, in a climate controlled room. If your treadmill has been exposed to colder temperatures or high moisture climates, it is strongly recommended that the treadmill is warmed up to room temperature before first time use. Failure to do so may cause premature electronic failure.

Assembly

IMPORTANT: PLEASE READ BEFORE USE!

CAUTION! There are several areas during the assembly process of a the treadmill that special attention must be paid. It is very important to follow the assembly instructions correctly and to make sure all parts are firmly tightened. If the assembly instructions are not followed correctly, the treadmill could have frame parts that are not tightened and will seem loose and may cause irritating noises. There should be no side-to-side play in the console masts or any forward and back play in the console assembly or handlebars. If there is any play in these areas, the treadmill has not been properly assembled. To prevent damage to the treadmill, the assembly instructions must be reviewed and corrective actions should be taken.

UNPACKING

Place your treadmill on a level flat surface. It is recommended that you place a protective covering on your floor. Take CAUTION when handling and transporting this unit. Never open box when it is on its side. Once the banding straps have been removed, do not lift or transport this unit unless it is fully assembled and in the upright folded position, with the lock latch secure. NOTE: The console assembly is located under the treadmill deck and should ONLY be removed after STEP 1 of the assembly instructions have been fully completed! **FAILURE TO DO SO MAY RESULT IN SERIOUS INJURY!** Unpack the unit where it will be used. The enclosed treadmill is equipped with high-pressure shocks and may spring open if mishandled. Never grab hold of any portion of the incline frame and attempt to lift or move the treadmill. **FAILURE TO FOLLOW THESE INSTRUCTIONS COULD RESULT IN INJURY!**

Before proceeding, find your treadmill's serial number and model name located to the left of the on/off power switch and power cord and enter it in the space provided below and be sure to read the Safety Instructions and complete User's guide section before using your new treadmill:

ENTER YOUR SERIAL NUMBER AND MODEL NAME IN THE BOX BELOW:

Refer to the serial number and model name when calling for service, also enter this serial number on your Warranty Card.

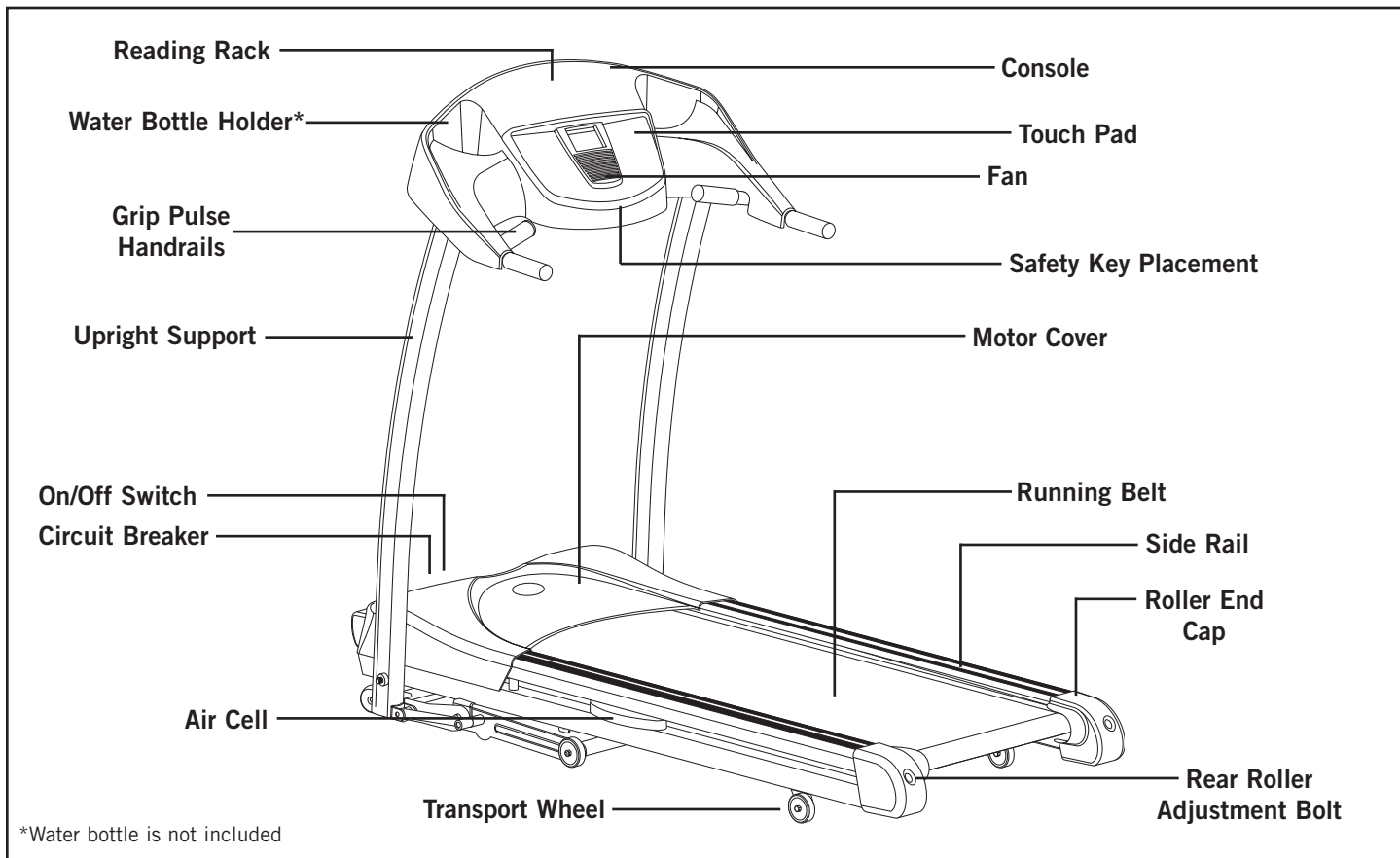

TOOLS (Included)

- 5mm Allen Wrench/Phillips Screw Driver • 8mm Allen Wrench or 6mm Allen Wrench

PARTS

- 1 Safety Key • 1 Console Assembly (located under treadmill deck) • 1 Power Cord • 1 Hardware Pack (contents listed)

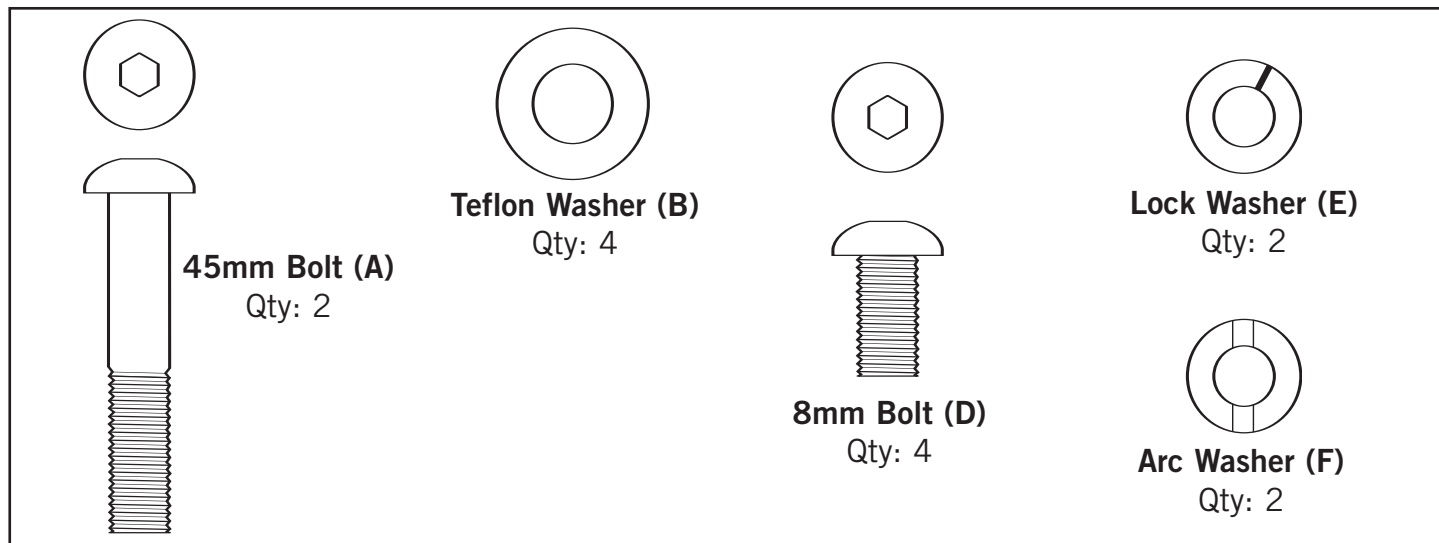

If you have questions, or if there are any missing parts, we will guarantee complete satisfaction.
PLEASE CALL OUR TOLL-FREE DIRECT CUSTOMER ASSISTANCE CENTER @ 1.888.993.3199
 Mon.-Fri., 8 a.m.-5 p.m. CST (excluding holidays).

NOTE: It is recommended that you apply grease to the threads of each bolt as you assemble your treadmill, to prevent loosening and noise. Also, during each assembly step, ensure that ALL nuts and bolts are in place and partially threaded in before completely tightening any ONE bolt.

Assembly Step 1

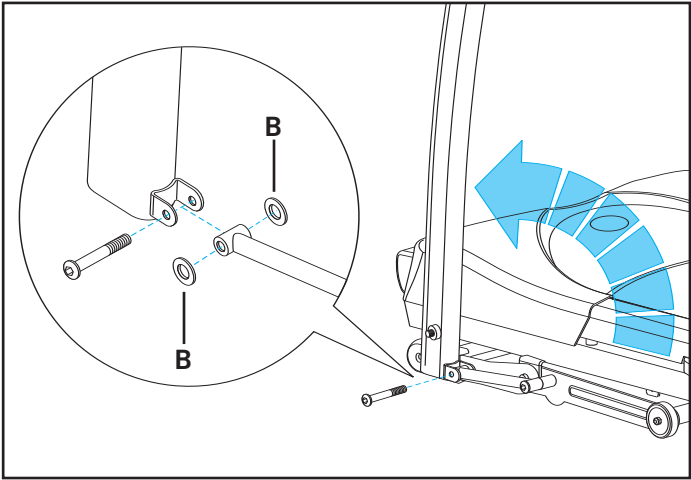

1. Lift left console mast into upright position. Be sure to hold the console mast firmly, as it will not stay in the upright position on it's own.
2. Move left side linkage arm, Teflon Washer (B) into position and insert bolt (A) and tighten.
3. Repeat on the right side.
4. Cut and remove the banding strap.

Assembly Step 2

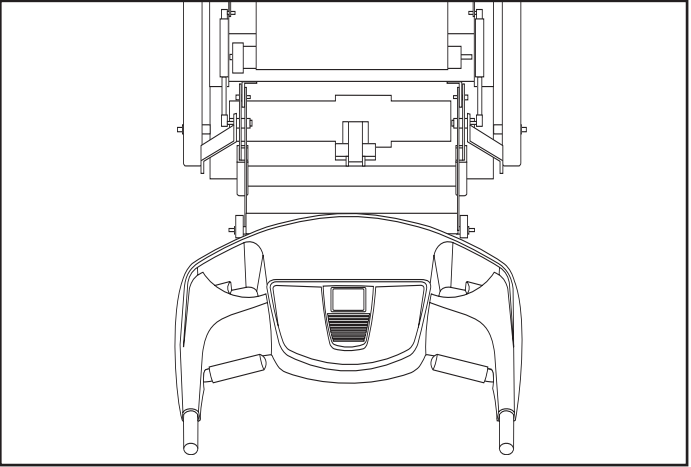

1. Lift the running deck until lock latch is fully engaged.
2. Remove console assembly from treadmill carton and place out of the way.
3. Lower the treadmill running deck from the folded position.

Assembly Step 3

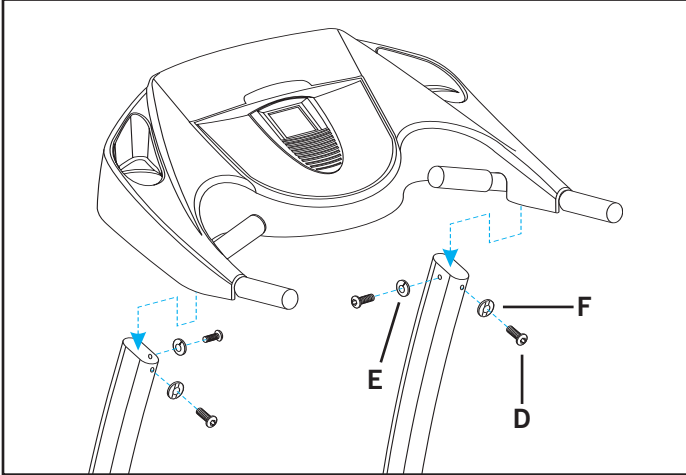

1. Place console assembly into its correct position.
2. Place Lock Washer (E) and bolt (D) into left upright support and tighten.
3. Place Arc Washer (F) and bolt (D) into left upright support and tighten.
4. Repeat STEPS 2 and 3 for the right-side upright support.

NOTE: Do not pinch console cable or grip pulse wires.

Assembly Step 4

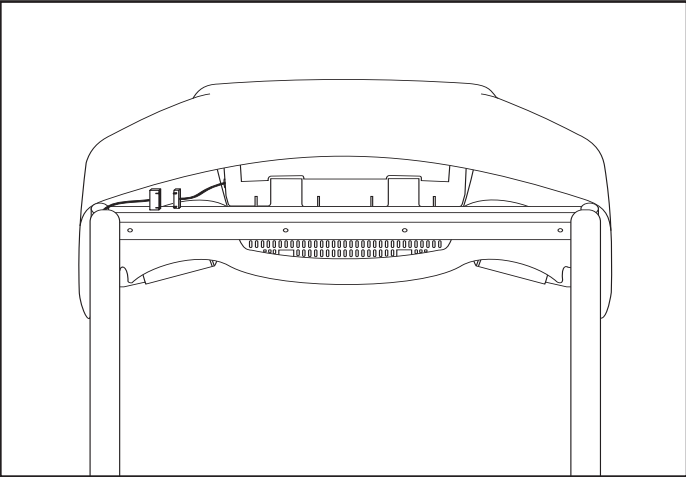

1. Connect the console cable. Carefully tuck wires in mast to avoid damage.

NOTE: Do not pinch the wires

FINISH

Before You Begin

CONGRATULATIONS! on choosing your treadmill. You've taken an important step in developing and sustaining an exercise program! Your treadmill is a tremendously effective tool for achieving your personal fitness goals. Regular use of your treadmill can improve the quality of your life in so many ways.

Here are just a few of the health benefits of exercise:

- Weight Loss • A Healthier Heart • Improved Muscle Tone • Increased Daily Energy Levels • Reduced Stress • Help In Countering Anxiety and Depression • An Improved Self Image

The key to reaping these benefits is to develop an exercise habit. Your new treadmill will help you eliminate the obstacles that prevent you from getting in your exercise time. Inclement weather and darkness won't interfere with your workout when you use your treadmill in the comfort of your home. This guide provides you with basic information for using and enjoying your new machine. A more complete knowledge of your new treadmill will assist you in realizing your goal of a healthy lifestyle.

TURN POWER ON

Make sure that your treadmill is properly connected to a power outlet. The on/off switch is located next to the power cord. Flip this switch to the 'on' position, so that the switch is lit. You will hear a beep and the console will light up.

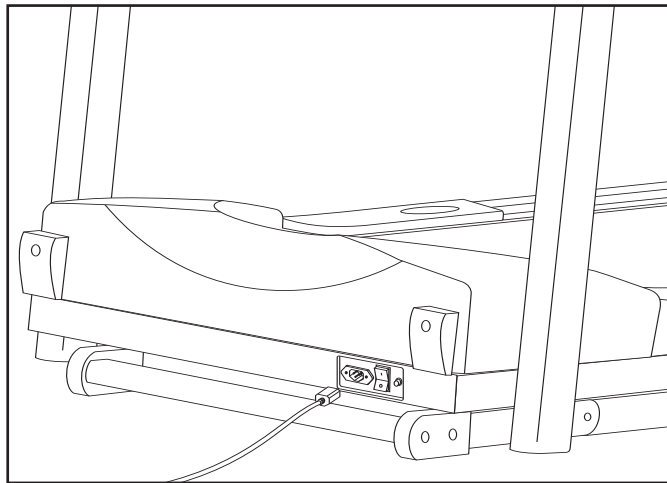

DO NOT STAND ON THE BELT

While you are preparing to use the treadmill, do not stand on the belt. Place your feet on the side rails before starting the treadmill. Start walking on the belt only after the belt has begun to move. Never start the treadmill at a fast running speed and attempt to jump on!

SAFETY KEY

Your treadmill will not start unless the safety key is placed in position. Attach the clip end securely to your clothing. This safety key is designed to cut the power to the treadmill if you should fall. **NEVER USE THE TREADMILL WITHOUT SECURING THE SAFETY KEY CLIP TO YOUR CLOTHING. PULL ON THE SAFETY KEY CLIP FIRST TO MAKE SURE IT WILL NOT COME OFF YOUR CLOTHING.**

FOLDING

Firmly grasp the back end of the treadmill. Carefully lift the end of the treadmill deck into the upright position until the foot lock latch engages and securely locks the deck into position. Make sure the deck is securely latched before letting go. To unfold, firmly grasp the back end of the treadmill. Gently press down on the foot lock latch with your foot until the lock latch disengages. Carefully lower the deck to the ground.

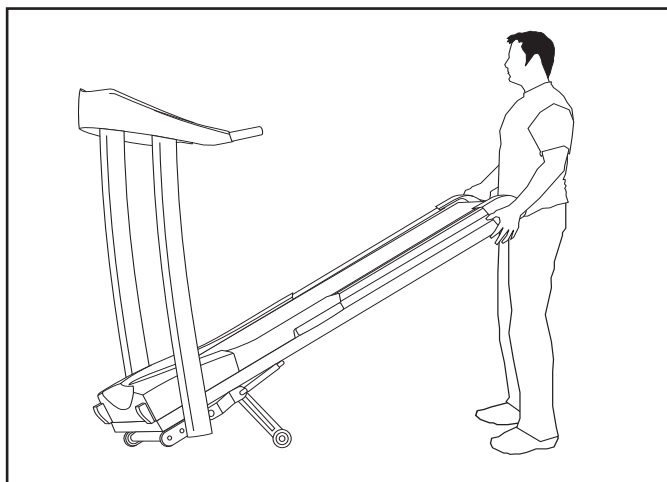

MOVING

Your treadmill has a pair of transport wheels built into the frame. To move, make sure the treadmill is folded and securely latched. Then firmly grasp the handlebars, tilt the treadmill back and roll. **CAUTION!** Our Treadmills are heavy, use care and additional help if necessary when moving. Do not attempt to move or transport treadmill unless it is in upright, folded position with the lock latch secured. Failure to follow these instructions could result in injury.

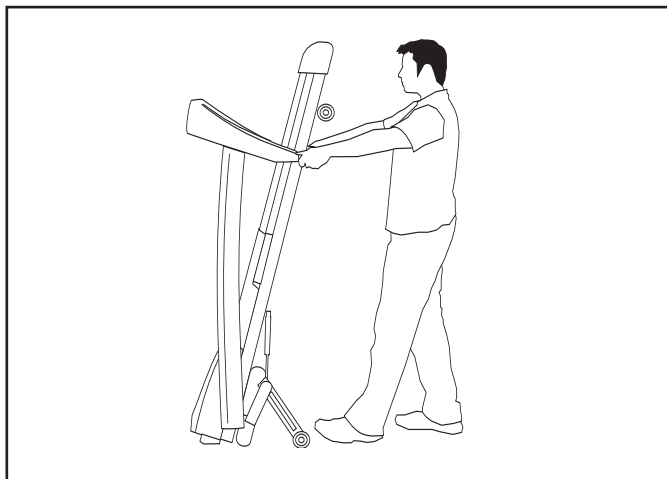

TENSIONING THE RUNNING BELT (NOTE: Running belt should NOT be moving during adjustments)
If you can feel a slipping sensation when running on the treadmill, the running belt must be tightened. In most cases, the belt has stretched from use, causing the belt to slip. This is a normal and common adjustment. To eliminate this slipping, turn the treadmill off and tension both the rear roller bolts with the appropriate size allen wrench, turning it 1/4 TURN to the right as shown. Turn the treadmill on and check for slipping. Repeat if necessary, but NEVER TURN the roller bolts more than 1/4 turn at a time. Belt is properly tensioned when the slipping sensation is gone.

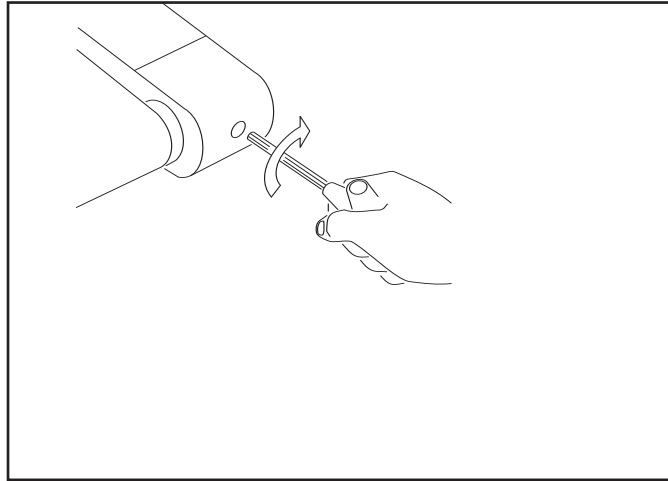

CENTERING THE RUNNING BELT (NOTE: Running belt should NOT be moving during adjustments)
If the running belt is too far to the right side: turn the right adjustment bolt clockwise 1/4 turn at a time. Turn the treadmill on and check the belt alignment. Repeat if necessary, until the belt remains centered during use (using the supplied Allen wrench).

If the running belt is too far to the left side: turn the right adjustment bolt counter-clockwise 1/4 turn at a time. Turn the treadmill on and check the belt alignment. Repeat if necessary, until the belt remains centered during use (using the supplied Allen wrench).

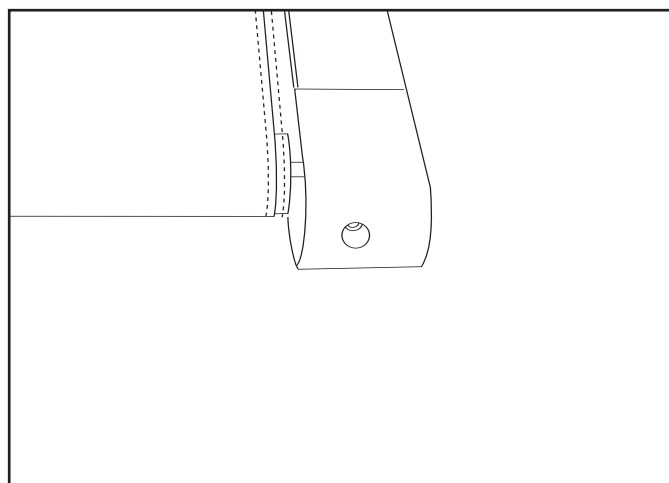

Operation

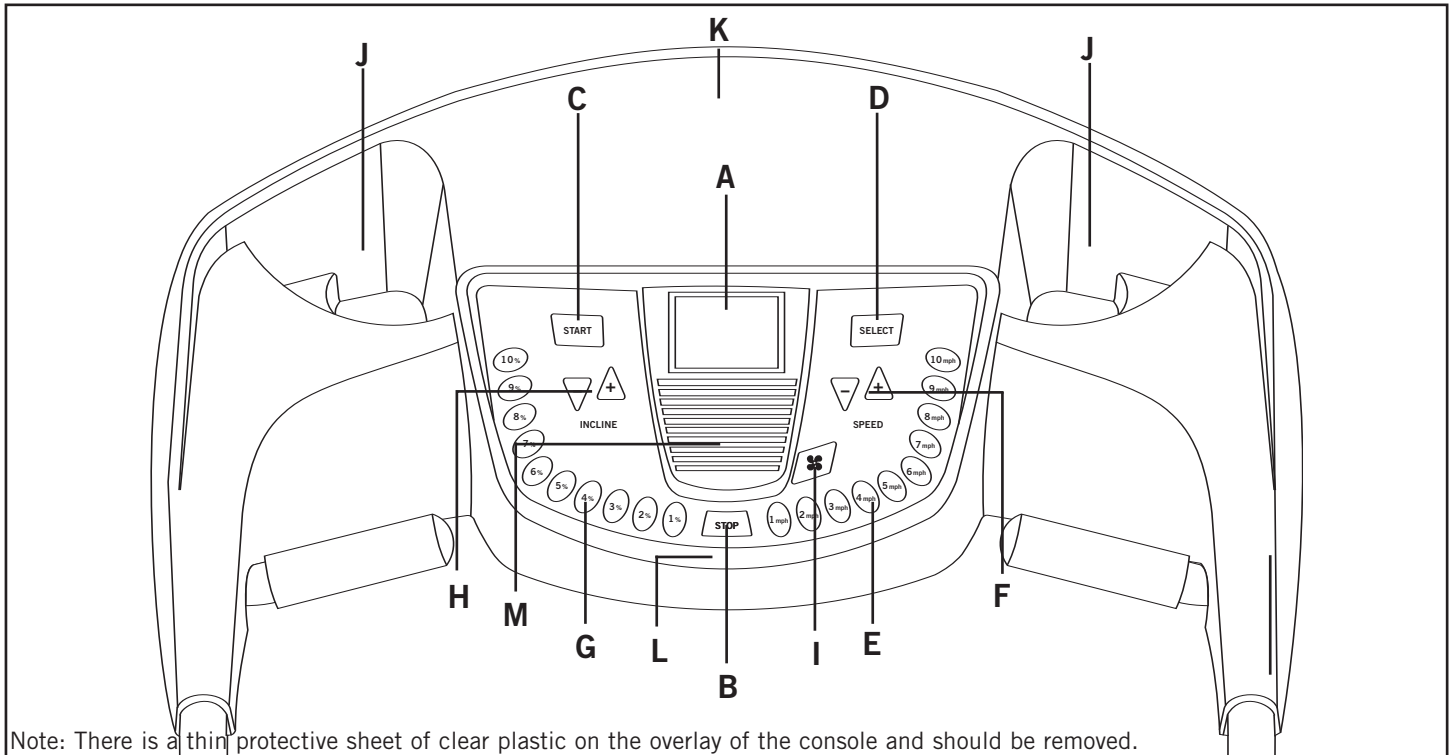

A. MONITOR DISPLAY: Speed, Time, Pulse, Distance, Incline, Calories and Program Profiles.

B. STOP: Press to pause/end your workout. Hold for 3 seconds to reset the treadmill.

C. START: Simply press to begin exercising or starts your program.

D. SELECT: Used to select Program, Level, Time or feedback during workout.

E. QUICK SPEED KEYS: Used to reach desired speed more quickly.

F. STANDARD SPEED KEYS: Used to adjust speed in small increments (.1 mph increments).

G. QUICK INCLINE KEYS: Used to reach desired incline more quickly.

H. STANDARD INCLINE KEYS: Used to adjust incline in small increments (.5% increments).

I. FAN BUTTON: Press the FAN button ON/LEVEL 1/LEVEL 2/LEVEL 3/OFF.

J. WATER BOTTLE/CD/MP3 HOLDERS: Holds personal workout equipment.

K. READING RACK: Holds reading material.

L. SAFETY KEY POSITION: Enables treadmill when safety key is inserted.

M. FAN: Personal workout fan.

MONITOR DISPLAY

SPEED

Indicates how fast your walking or running surface is moving.

TIME

Shown as Minutes:Seconds. View the time remaining or the time elapsed in your workout.

PULSE

Shown as Beats Per Minute. Used to monitor your heart rate (displayed when contact is made with both pulse grips or wireless chest is used - included with select models only).

DISTANCE

Distance traveled during your workout.

INCLINE

Shown as Percent. Indicates the incline of your walking or running surface.

CALORIES

Total calories burned during your workout.

PROGRAM PROFILES

Represents the profile of the program being used (speed during speed based programs and incline during incline based programs).

HEART RATE

HANDLEBARS

Place the palm of your hands directly on the grip pulse handlebars. Both hands must grip the bars for your heart rate to register. When gripping the pulse handlebars, do not grip tightly. Holding the grips tightly may elevate your blood pressure. Keep a loose, cupping hold. You may experience an erratic readout if consistently holding the grip pulse handlebars.

PROGRAMMING

QUICK START UP

Simply press the START key to begin working out.

SELECT A PROGRAM

Select a PROGRAM using the SPEED keys. Once a PROGRAM has been chosen, press SELECT.

SELECT A LEVEL

Select a PROGRAM LEVEL using the SPEED keys. Once a PROGRAM LEVEL has been chosen, press SELECT.

SELECT A TIME

Select a Time using the SPEED keys or use the default time. Once a TIME has been chosen, press START.

FINISHING YOUR WORKOUT

When your workout is complete, the MONITOR DISPLAY will flash and beep. Your workout information will stay displayed on the console for 30 seconds and then reset.

PROGRAMS

MANUAL

Allows 'On The Fly' manual speed and incline changes. Time-based goal (T605 & T805 models).

INTERVALS - Walk or run a series of alternating paced levels. Time-based goal with 10 difficulty levels to choose from (T605 & T805 models).

Program Segments

(peak segments last 30 seconds, valley segments last 90 seconds)

	Warm-up		1	2	3	4	Segments are repeated until selected time is reached.	Cool-down	
Level 1	1.0	1.5	2.0	4.0	2.0	4.0		1.5	1.0
Level 2	1.0	1.5	2.0	4.5	2.0	4.5		1.5	1.0
Level 3	1.3	1.9	2.5	5.0	2.5	5.0		1.9	1.3
Level 4	1.3	1.9	2.5	5.5	2.5	5.5		1.9	1.3
Level 5	1.5	2.3	3.0	6.0	3.0	6.0		2.3	1.5
Level 6	1.5	2.3	3.0	6.5	3.0	6.5		2.3	1.5
Level 7	1.8	2.6	3.5	7.0	3.5	7.0		2.6	1.8
Level 8	1.8	2.6	3.5	7.5	3.5	7.5		2.6	1.8
Level 9	2.0	3.0	4.0	8.0	4.0	8.0		3.0	2.0
Level 10	2.0	3.0	4.0	8.5	4.0	8.5	3.0	2.0	

(warm-up and cool-down last 5:00 minutes each and are included in program times)

WEIGHT LOSS - Challenges with various combinations of hills and valleys. Time-based goal with 10 difficulty levels to choose from (T605 & T805 models).

Program Segments (all segments last 10 seconds)

		Warm Up	1	2	3	4	5	6	7	8	Segments are repeated until selected time is reached.	Cool Down		
Level 1	Elevation	0.0	0.5	1.5	1.5	1.0	0.5	0.5	1.0	1.5		0.5	0.0	
	Speed	1.0	1.5	2.0	2.5	3.0	3.5	4.0	3.5	3.0		2.5	2.3	1.5
Level 2	Elevation	0.0	0.5	1.5	1.5	1.0	0.5	1.0	0.5	1.0		1.5	0.5	0.0
	Speed	1.3	1.9	2.5	3.0	3.5	4.0	4.5	4.0	3.5		3.0	2.6	1.8
Level 3	Elevation	0.5	1.0	2.0	2.0	1.5	1.0	1.0	1.0	1.5		2.0	1.0	0.5
	Speed	1.5	2.3	3.0	3.5	4.0	4.5	5.0	4.5	4.0		3.5	3.0	2.0
Level 4	Elevation	0.5	1.0	2.0	2.0	1.5	1.0	1.0	1.0	1.5		2.0	1.0	0.5
	Speed	1.8	2.6	3.5	4.0	4.5	5.0	5.5	5.0	4.5		4.0	3.4	2.3
Level 5	Elevation	1.0	1.5	2.5	2.5	2.0	1.5	1.5	1.5	2.0		2.5	1.0	1.5
	Speed	2.0	3.0	4.0	4.5	5.0	5.5	6.0	5.5	5.0		4.5	3.8	2.5
Level 6	Elevation	1.0	1.5	2.5	2.5	2.0	1.5	1.5	1.5	2.0		2.5	1.0	1.5
	Speed	2.3	3.4	4.5	5.0	5.5	6.0	6.5	6.0	5.5		5.0	4.1	2.8
Level 7	Elevation	1.5	2.0	3.0	3.0	2.5	2.0	2.0	2.0	2.5		3.0	2.0	1.5
	Speed	2.5	3.8	5.0	5.5	6.0	6.5	7.0	6.5	6.0		5.5	4.5	3.0
Level 8	Elevation	1.5	2.0	3.0	3.0	2.5	2.0	2.0	2.0	2.5		3.0	2.0	1.5
	Speed	2.8	4.1	5.5	6.0	6.5	7.0	7.5	7.0	6.5		6.0	4.9	3.3
Level 9	Elevation	2.0	2.5	3.5	3.5	3.0	2.5	2.5	2.5	3.0		3.5	2.5	2.0
	Speed	3.0	4.5	6.0	6.5	7.0	7.5	8.0	7.5	7.0		6.5	5.3	3.5
Level 10	Elevation	2.0	2.5	3.5	3.5	3.0	2.5	2.5	2.5	3.0		3.5	2.5	2.0
	Speed	3.3	4.9	6.5	7.0	7.5	8.0	8.5	8.0	7.5	7.0	5.6	3.8	

(warm-up and cool-down last 5:00 minutes each and are included in program times)

GOLF COURSE - Simulates various inclines and yardages for holes on a golf course, with 4 tee-off boxes and 9 or 18 holes to choose from. Distance-based goal (T605 & T805 models).

Program Segments

		hole 1	hole 2	hole 3	hole 4	hole 5	hole 6	hole 7	hole 8	hole 9	hole 10	hole 11	hole 12	hole 13	hole 14	hole 15	hole 16	hole 17	hole 18	Total Distance
Red tee 9 holes	Elevation	0.0	1.0	2.0	3.0	2.5	1.0	2.0	2.5	1.5										2482
	Distance	309	359	283	256	113	387	91	351	333										
White tee 9 holes	Elevation	0.0	1.0	2.0	3.0	2.5	1.0	2.0	2.5	1.5										2875
	Distance	331	427	330	295	129	466	97	369	431										
Blue tee 9 holes	Elevation	0.0	1.0	2.0	3.0	2.5	1.0	2.0	2.5	1.5										3003
	Distance	345	460	337	308	142	484	97	389	441										
Black tee 9 holes	Elevation	0.0	1.0	2.0	3.0	2.5	1.0	2.0	2.5	1.5										3250
	Distance	376	502	374	327	187	500	106	416	462										
Red tee 18 holes	Elevation	0.0	1.0	2.0	3.0	2.5	1.0	2.0	2.5	1.5	3.5	2.5	2.0	4.0	2.5	3.0	2.0	5.0	2.0	5198
	Distance	309	359	283	256	113	387	91	351	333	301	301	165	288	434	312	310	150	455	
White tee 18 holes	Elevation	0.0	1.0	2.0	3.0	2.5	1.0	2.0	2.5	1.5	3.5	2.5	2.0	4.0	2.5	3.0	2.0	5.0	2.0	6116
	Distance	331	427	330	295	129	466	97	369	431	407	339	179	368	548	349	376	166	509	
Blue tee 18 holes	Elevation	0.0	1.0	2.0	3.0	2.5	1.0	2.0	2.5	1.5	3.5	2.5	2.0	4.0	2.5	3.0	2.0	5.0	2.0	6348
	Distance	345	460	337	308	142	484	97	389	441	413	349	187	376	560	373	383	383	532	
Black tee 18 holes	Elevation	0.0	1.0	2.0	3.0	2.5	1.0	2.0	2.5	1.5	3.5	2.5	2.0	4.0	2.5	3.0	2.0	5.0	2.0	6737
	Distance	376	502	374	327	187	500	106	416	462	430	373	201	393	572	396	401	178	543	

RACE (T805 model only)

Challenge the computer to a Race, customize pace speed and distance. Program is designed to add motivation to a workout by allowing you to complete against a selected pacer.

1. Once the RACE PROGRAM has been chosen, press SELECT.
2. Choose a desired Pace (speed) using the SPEED keys and press SELECT. The selected pace is the pace you will be racing against. You will choose your own speed **after** the program has started and WARM-UP is complete.
3. To choose your desired distance press the SPEED keys and press SELECT.
4. Press START to begin workout.

Note: this is a distance-based program, the time it will take you to complete the race is determined by the speed and distance selected.

- Upon pressing START, the program will be broken up into 13 segments. The first segment will be dedicated to a WARM-UP, which will be half of the selected pace (Speed). The middle segments will consist of the RACE, with the last segment dedicated to a COOL-DOWN, which will be half of the selected Pace (your speed will automatically be reduced for cool-down segment). **NOTE:** The race distance does not include the time for WARM-UP and COOL-DOWN (as they are a set time of 2.5 minutes each).
- You can adjust your own speed at any time during the program by pressing the SPEED keys or by using the QUICK SPEED keys.
- You can set the Pace (speed) from 1.0 mph - 10.0 mph (in .5 mph increments) and Distance from 1 - 10 miles (in 1 mile increments).
- If you beat the pacer to the finish line, the console will flash and scroll YOU WIN and begin your cool-down. If the pacer wins, the console will flash and scroll PACER WINS and begin your cool-down.

USER 1 (T805 model only)

Lets you create and reuse a perfect workout for you with specific speed, incline and time combination. The ultimate in personal programming. Time-based goal.

- 1.** Once the USER 1 program has been chosen, press SELECT.
 - 2.** Choose the desired TIME using the SPEED keys and press SELECT.
 - 3.** Choose the desired SPEED for each segment, using the SPEED keys and press SELECT. Note: You will need to press SELECT after each segment.
 - 4.** Choose the desired INCLINE for each segment, using the SPEED keys and press SELECT. Note: You will need to press SELECT after each segment.
 - 5.** Press START to begin your program. At this time, your program has been successfully saved into memory, and can be used for future workouts.
- To reset your program information and delete it from memory, press and hold the SELECT key for 5 seconds (after you have selected the USER 1 program).
 - While using your saved program, you are able to adjust the speed or incline, but any changes will not be saved.

Troubleshooting & Maintenance Procedures

COMMON PRODUCT QUESTIONS

ARE THE SOUNDS MY TREADMILL MAKES NORMAL?

All treadmills make a certain type of thumping noise due to the belt riding over the rollers, especially new treadmills. This noise will diminish over time, although may not totally go away. Over time, the belt will stretch, causing the belt to ride smoother over the rollers.

WHY IS THE TREADMILL I HAD DELIVERED LOUDER THAN THE ONE AT THE STORE?

All fitness products seem quieter in a large store showroom because there is generally more background noise than in your home. Also, there will be less reverberation on a carpeted concrete floor than on a wood overlay floor. Sometimes a heavy rubber mat will help reduce reverberation through the floor. If a fitness product is placed close to a wall, there will be more reflected noise.

WHEN SHOULD I BE WORRIED ABOUT A NOISE?

As long as the sounds your treadmill makes are no louder than a normal conversational tone of voice, it is considered normal noise.

TROUBLESHOOTING - TREADMILL

Your treadmill is designed to be reliable and easy to use. However, if you experience a problem, please reference the troubleshooting guide listed below.

PROBLEM: The console does not light up.

SOLUTION: Verify that the power cord is plugged in properly to the outlet, and that the treadmill switch is turned on.

PROBLEM: The treadmill circuit breaker trips during a workout.

SOLUTION: Verify that the treadmill is plugged into a dedicated 20amp circuit, that it is NOT plugged into an extension cord and that it is NOT plugged into a GFCI-equipped outlet.

PROBLEM: The treadmill shuts off when elevating.

SOLUTION: Verify that there is enough slack in the power cord to reach to the wall outlet during elevation.

TROUBLESHOOTING - TREADMILLS

PROBLEM: The running belt does not stay centered during a workout.

SOLUTION: Verify that the treadmill is on a level surface. Verify that the belt is properly tightened and centered (Refer to the ADJUSTMENT section)

TROUBLESHOOTING - HEART RATE

Check your exercise environment for sources of interference such as fluorescent lights, computers, or appliances containing large motors. These items may cause erratic heart rate readouts.

You may experience an erratic readout under the following conditions:

- Gripping the heart rate handlebars too tight. Try to maintain moderate pressure while holding onto the heart rate handlebars.
- Constant movement and vibration due to constantly holding the heart rate handlebars while exercising. If you are receiving erratic heart rate readouts, try to only hold the grips long enough to monitor your heart rate.
- When you are breathing heavily during a workout.
- When your hands are constricted by wearing a ring.
- When your hands are dry or cold. Try to moisten your palms by rubbing them together to warm.
- Anyone with heavy arrhythmia.
- Anyone with arteriosclerosis or peripheral circulation disorder.
- Anyone whose skin on the measuring palm is especially thick.

**If the above troubleshooting section does not remedy the problem,
discontinue use and turn the power off.**

PLEASE CALL OUR TOLL-FREE DIRECT CUSTOMER ASSISTANCE CENTER @ 1.888.993.3199

Mon.-Fri., 8 a.m.-5 p.m. CST (excluding holidays).

MAINTENANCE

Cleanliness of your treadmill and its operation environment will keep maintenance problems and service calls to a minimum. For this reason, we recommend that the following preventive maintenance schedule be followed.

AFTER EACH USE (DAILY)

Clean and inspect, following these steps:

- Turn off the treadmill with the on/off switch, then unplug the power cord at the wall outlet.
- Wipe down the running belt, deck, motor cover, and console casing with a damp cloth. Never use solvents, as they can cause damage to the treadmill.
- Inspect the power cord. If the power cord is damaged, contact Horizon Fitness.
- Make sure the power cord is not underneath the treadmill or in any other area where it can become pinched or cut.
- Check the tension and alignment of the running belt. Make sure that the treadmill belt will not damage any other components on the treadmill by being misaligned.

EVERY WEEK

Clean underneath the treadmill, following these steps:

- Turn off the treadmill with the on/off switch, then unplug the power cord at the wall outlet.
- Fold the treadmill into the upright position, making sure that the lock latch is secure.
- Move the treadmill to a remote location.
- Wipe or vacuum any dust particles or other objects that may have accumulated underneath the treadmill.
- Return the treadmill to its previous position.

EVERY MONTH

- Turn off the treadmill with the on/off switch, then unplug the power cord at the wall outlet.
- Inspect all assembly bolts of the machine for proper tightness.
- Remove the motor cover and clean the motor and lower board area to eliminate any lint or dust particles that may have accumulated. Failure to do so may result in premature failure of key electrical components.

EVERY 6 MONTHS

It may be necessary to lubricate your treadmill running deck every six months to maintain optimal performance of your treadmill. Only use lubricant provided by Horizon Fitness! Please contact Horizon Fitness with questions about applying lubricant to your treadmill.

- Turn off the treadmill with the on/off switch, then unplug the power cord at the wall outlet.
- Loosen both the rear roller bolts. (for best results, place two removable marks on both sides of the frame and note roller position). Once the belt is loosened, take the bottle of lubricant and apply it to the entire top surface of the running deck. Tighten both rear roller bolts (matching up the marks for proper position) to original position. After you have applied lubricant, plug in the power cord, insert the safety key, start the treadmill and walk on the belt for two minutes to spread the lubricant.
- Lubricate the air shocks with teflon based spray.

Conditioning Guidelines

Always consult your physician before beginning an exercise program.

HOW OFTEN?

The American Heart Association recommends that you exercise at least 3 to 4 days per week to maintain cardiovascular fitness. If you have other goals such as weight or fat loss, you will achieve your goal faster with more frequent exercise. Whether it's 3 days or 6 days, remember that your ultimate goal should be to make exercise a lifetime habit. Many people are successful staying with a fitness program if they set aside a specific time of day to exercise. It doesn't matter whether it's in the morning before your shower, during lunch hour or while watching the evening news. What's more important is that it's a time that allows you to keep a schedule, and a time when you won't be interrupted. If you are to be successful with your fitness program, you have to make it a priority in your life. So decide on a time, pull out your day planner and pencil in your exercise times for the next month!

HOW LONG?

For aerobic exercise benefits, it's recommended that you exercise from between 24 and 32 minutes per session. But start slowly and gradually increase your exercise times. If you've been sedentary during the past year, it may be a good idea to keep your exercise times to as little as five minutes initially. Your body will need time to adjust to the new activity. If your goal is weight loss, a longer exercise session at lower intensities has been found to be most effective. A workout time of 48 minutes or more is recommended for best weight loss results.

HOW HARD?

How hard you workout is also determined by your goals. If you use your treadmill to prepare for a 5K run, you will probably work out at a higher intensity than if your goal is general fitness. Regardless of your long term goals, always begin an exercise program at low intensity. Aerobic exercise does not have to be painful to be beneficial! There are two ways to measure your exercise intensity. The first is by monitoring your heart rate (using the grip pulse handlebars or a wireless chest transmitter-sold separately), and the second is by evaluating your perceived exertion level (this is simpler than it sounds!).

PERCEIVED EXERTION LEVEL

A simple way to gauge your exercise intensity is to evaluate your perceived exertion level. While exercising if you are too winded to maintain a conversation without gasping, you are working out too hard. A good rule of thumb is to work to the point of exhilaration, not exhaustion. If you cannot catch your breath, it's time to slow down. Always be aware of the warning signs of overexertion.

TARGET ZONE HEART RATE CHART

Your Target Zone is a percentage of your maximum heart rate. Target Zone will vary for each individual, depending on age, current level of conditioning, and personal fitness goals. The American Heart Association recommends working-out at a Target Heart Rate Zone of between 60% and 75% of your maximum heart rate. See the chart below for convenient reference.

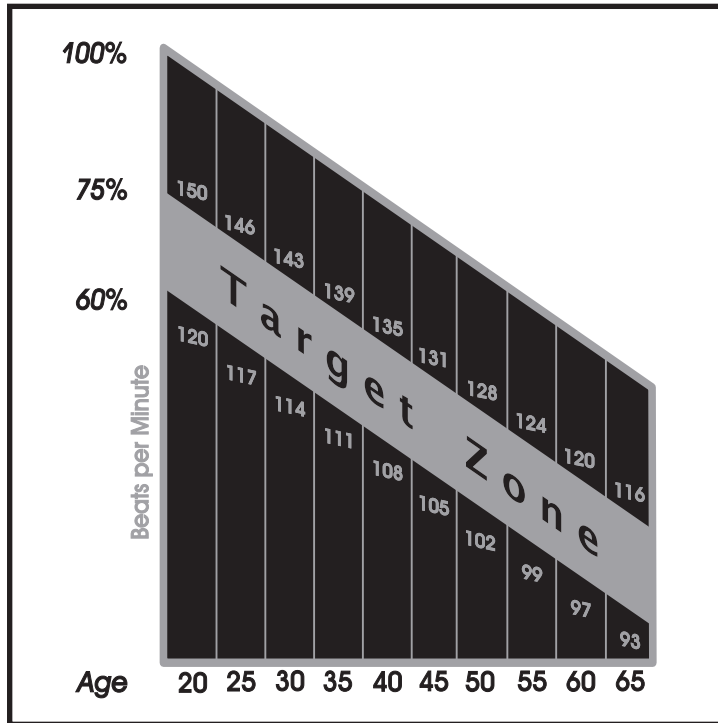

EXAMPLE: for a 42-year old user: find AGE along the bottom of the chart (round to 40), follow AGE column up to the TARGET ZONE BAR. RESULTS: 60% of maximum Hear Rate = 108 Beats Per Minute, 75% of maximum Heart Rate = 135 Beat Per Minute.

DEVELOPING A FITNESS PROGRAM



STRETCH FIRST

Before using your product, it is best to take a few minutes doing a few gentle stretching exercises. Stretching prior to exercise will improve flexibility and reduce chances of exercise related injury. Ease into each of these stretches with a slow gentle motion. Do not stretch to the point of pain. Make sure not to bounce while doing these stretches.

WALL PUSH

Stand near a wall with the toes of one foot about 18" from the wall, and the other foot about 12" behind the other foot. Lean forward, pushing against the wall with your palms. Keep your heels flat and hold this position for a count of 15 seconds. Make sure that you do not bounce while stretching. Alternate positions of your feet and repeat for a total of 8 repetitions.

STANDING QUADRICEPS STRETCH

Using a wall to provide balance, grasp your left ankle with your left hand and hold your foot against the back of your thigh for a count of 15 seconds. Repeat with your right ankle and hand, and continue alternating for a total of 8 repetitions.

SEATED TOE TOUCH

Sit on the floor with your legs together and straight out in front of you. Do not lock your knees. Extend your fingers towards your toes and hold for a count of 15 seconds. Make sure that you do not bounce while stretching. Sit upright again. Repeat for a total of 8 repetitions.

THE IMPORTANCE OF WARM UP & COOL DOWN

WARM UP

The first 2 to 5 minutes of a workout should be devoted to warming up. The warm-up will limber your muscles and prepare them for more strenuous exercise. Make sure that you warm-up on your product at a slow pace.

COOL DOWN

Never stop exercising suddenly! A cool-down period allows your heart to readjust to the decreased demand. Make sure that your cool down period consists of a very slow pace to allow your heart rate to lower. After the cool-down, repeat the stretching exercises listed above to loosen and relax your muscles.

ACHIEVING YOUR FITNESS GOALS

An important step in developing a long term fitness program is to determine your goals. Is your primary goal for exercising on your treadmill to lose weight? Improve muscle? Burn stress? Prepare for the spring racing schedule? Knowing what your goals are will help you develop a more successful exercise program. Below are some common exercise goals:

- Weight Loss
- Improve Body Shape and Tone
- Increased Energy Level
- Improved Sports Performance
- Improved Cardiovascular Endurance
- Weight Maintenance
- Strengthen Leg Muscles
- Improved Sleep Patterns
- Stress Reduction

If possible try to define your personal goals in precise, measurable terms, and then put your goals in writing. The more specific you can be, the easier it will be to track your progress. If your goals are long term, divide them up into monthly and weekly segments. Longer term goals can lose some of the immediate motivation benefits. Short term goals are easier to achieve. Your treadmill console provides you with several readouts that can be used to record your progress. You can track Distance, Calories or Time. Time is the most important and useful of test functions.

KEEPING AN EXERCISE DAIRY

Photocopy the weekly and monthly log sheets which are located near the end of this user guide to make your personal exercise log book. As time goes by you'll be able to look back with pride at the work you've done. As your fitness improves, you can look back and see how far you've come.

WEEK #		WEEKLY GOAL:			
DAY	DATE	DISTANCE	CALORIES	TIME	COMMENTS
SUN	0/0/00	0	0	0:00	
MON					
TUES					
WED					
THUR					
FRI					
SAT					
WEEKLY TOTALS		0	0	0:00	

MONTH		MONTHLY GOAL:		
WEEK #	DISTANCE	CALORIES	TIME	
0	0	0	0:00	
MONTHLY TOTALS	0	0	0:00	

Weekly Log Sheets

WEEK # _____		WEEKLY GOAL: _____			
DAY	DATE	DISTANCE	CALORIES	TIME	COMMENTS
SUN					
MON					
TUES					
WED					
THUR					
FRI					
SAT					
WEEKLY TOTALS					

WEEK # _____		WEEKLY GOAL: _____			
DAY	DATE	DISTANCE	CALORIES	TIME	COMMENTS
SUN					
MON					
TUES					
WED					
THUR					
FRI					
SAT					
WEEKLY TOTALS					

Weekly Log Sheets

WEEK # _____		WEEKLY GOAL: _____			
DAY	DATE	DISTANCE	CALORIES	TIME	COMMENTS
SUN					
MON					
TUES					
WED					
THUR					
FRI					
SAT					
WEEKLY TOTALS					

WEEK # _____		WEEKLY GOAL: _____			
DAY	DATE	DISTANCE	CALORIES	TIME	COMMENTS
SUN					
MON					
TUES					
WED					
THUR					
FRI					
SAT					
WEEKLY TOTALS					

Monthly Log Sheets

MONTH _____		MONTHLY GOAL: _____	
WEEK #	DISTANCE	CALORIES	TIME
MONTHLY TOTALS			

MONTH _____		MONTHLY GOAL: _____	
WEEK #	DISTANCE	CALORIES	TIME
MONTHLY TOTALS			

Monthly Log Sheets

MONTH _____		MONTHLY GOAL: _____	
WEEK #	DISTANCE	CALORIES	TIME
MONTHLY TOTALS			

MONTH _____		MONTHLY GOAL: _____	
WEEK #	DISTANCE	CALORIES	TIME
MONTHLY TOTALS			

Limited Warranty

FRAME • LIFETIME

Horizon Fitness warrants the frame against defects in workmanship and materials for the lifetime of the original owner.

DRIVE MOTOR/ELEVATION • 7 YEARS (Model T605)

Horizon Fitness warrants the drive/elevation motors against defects in workmanship and materials for a period of seven years from the date of purchase, so long as the device remains in the possession of the original owner.

DRIVE MOTOR/ELEVATION • 10 YEARS (Model T805)

Horizon Fitness warrants the drive/elevation motors against defects in workmanship and materials for a period of ten years from the date of purchase, so long as the device remains in the possession of the original owner.

ELECTRONICS & PARTS • 1 YEAR

Horizon Fitness warrants the electronic components, finish and all original parts for a period of one year from the date of original purchase, so long as the device remains in the possession of the original owner.

LABOR • 1 YEAR

Horizon Fitness shall cover the labor cost for the repair of the device for a period of one year from the date of the original purchase, so long as the device remains in the possession of the original owner.

EXCLUSIONS AND LIMITATIONS

This warranty applies only to the original owner and is not transferable. This warranty is expressly limited to the repair or replacement of a defective frame, motor, electronic component, or defective part and is the sole remedy of the warranty. The warranty does not cover normal wear and tear, improper assembly or maintenance, or installation of parts or accessories not originally intended or compatible with the Treadmill as sold. The warranty does not apply to damage or failure due to accident, abuse, corrosion, discoloration of paint or plastic, or neglect. Horizon Fitness shall not be responsible for incidental or consequential damages. All returns must be pre-authorized by Horizon Fitness. Horizon Fitness' obligation under this warranty is limited to replacing or repairing, at Horizon Fitness' option, the product at one of its authorized service centers. An Horizon Fitness authorized service center must receive all products for which a warranty claim is made. These products must be received with all freight and other transportation charges prepaid, accompanied by sufficient proof of purchase. Parts and electronic components reconditioned to As New Condition by Horizon Fitness or its vendors may sometimes be supplied as warranty replacement parts and constitute fulfillment of warranty terms. This warranty gives you specific legal rights, and your rights may vary from state to state.



Designed for life.™

HORIZON FITNESS
800 BURTON BOULEVARD
DEFOREST, WISCONSIN 53532
phone 1.888.993.3199 FAX 1.608.842.1660
www.horizonfitness.com